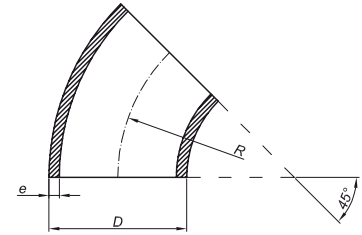

CODOS Y UNIONES

9

pág.

2	CODOS DE ALUMINIO ALUSKIT
4	REDUCCIONES DE ALUMINIO ALUSKIT
5	COLLARINES DE ALUMINIO ALUSKIT
6	BRIDAS DE ALUMINIO

CODOS A 45°

Codos de radio corto

Aleación	Rango DN/NB	Rango de diámetro D (mm)	Rango de espesor e (mm)	Rango de radio R (mm)	Norma
5083 - 0	1-20	33,4-508,0	3,05-15,08	25-508	EN 754/755
5083 - 0	14-24	355,6-609,6	6,35-17,47	356-610	EN 485
1050 - 0	40-150	50-160	2,5-5,0	38-152	EN 754/755
5754 - 0/H112	40-150	45-160	2,5-5,0	38-152	EN 754/755
6060 - T66	40-150	50-160	2,5-5,0	38-125	EN 755

Codos de radio largo

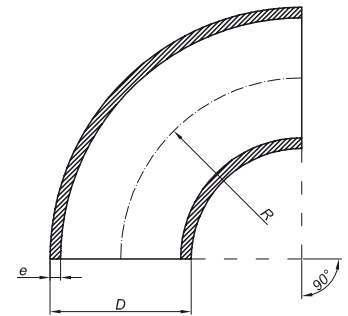
Aleación	Rango DN/NB	Rango de diámetro D (mm)	Rango de espesor e (mm)	Rango de radio R (mm)	Norma
5083 - 0	1-16	33,4-406,4	1,65-12,7	38-610	EN 754/755
5083 - 0	14-28	355,6-711,2	6,35-17,47	533-1067	EN 485
1050 - 0	15-200	21-219	2,5-5,0	27,5-305	EN 754/755
1050 - 0	250-800	273-813	3,0-10,0	381-1219	EN 485
1070 - 0	50-100	60-114	3,0-5,0	76-152	EN 754/755
5754 - 0/H112	15-200	21-219	2,5-5,0	27,5-305	EN 754/755
5754 - 0/H112	250-800	273-813	3,0-10,0	381-1219	EN 485
6060 - T66	15-200	21-219	2,5-5,0	27,5-305	EN 755

CODOS A 90°

Codos de radio corto

Aleación	Rango DN/NB	Rango de diámetro D (mm)	Rango de espesor e (mm)	Rango de radio R (mm)	Norma
5083 - 0	1-20	33,4-508,0	3,05-15,08	25-508	EN 754/755
5083 - 0	14-24	355,6-609,6	6,35-17,47	356-610	EN 485
1050 - 0	40-150	50-160	2,5-5,0	38-152	EN 754/755
5754 - 0/H112	40-150	45-160	2,5-5,0	38-152	EN 754/755
6060 - T66	40-150	50-160	2,5-5,0	38-125	EN 755

Codos de radio largo

Aleación	Rango DN/NB	Rango de diámetro D (mm)	Rango de espesor e (mm)	Rango de radio R (mm)	Norma
5083 - 0	1-16	33,4-406,4	1,65-12,7	38-610	EN 754/755
5083 - 0	14-28	355,6-711,2	6,35-17,47	533-1067	EN 485
1050 - 0	15-200	21-219	2,5-5,0	27,5-305	EN 754/755
1050 - 0	250-800	273-813	3,0-10,0	381-1219	EN 485
1070 - 0	50-100	60-114	3,0-5,0	76-152	EN 754/755
5754 - 0/H112	15-200	21-219	2,5-5,0	27,5-305	EN 754/755
5754 - 0/H112	250-800	273-813	3,0-10,0	381-1219	EN 485
6060 - T66	15-200	21-219	2,5-5,0	27,5-305	EN 755

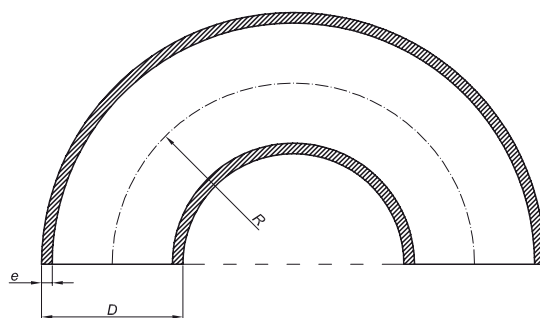
CODOS A 180°



Codos de radio corto

Aleación	Rango DN/NB	Rango de diámetro D (mm)	Rango de espesor e (mm)	Rango de radio R (mm)	Norma
5083 - 0	1-20	33,4-508,0	3,05-15,08	25-508	EN 754/755
5083 - 0	14-24	355,6-609,6	6,35-17,47	356-610	EN 485
1050 - 0	40-150	50-160	2,5-5,0	38-152	EN 754/755
5754 - 0/H112	40-150	45-160	2,5-5,0	38-152	EN 754/755
6060 - T66	40-150	50-160	2,5-5,0	38-125	EN 755

Codos de radio largo

Aleación	Rango DN/NB	Rango de diámetro D (mm)	Rango de espesor e (mm)	Rango de radio R (mm)	Norma
5083 - 0	1-16	33,4-406,4	1,65-12,7	38-610	EN 754/755
5083 - 0	14-28	355,6-711,2	6,35-17,47	533-1067	EN 485
1050 - 0	15-200	21-219	2,5-5,0	27,5-305	EN 754/755
1050 - 0	250-800	273-813	3,0-10,0	381-1219	EN 485
1070 - 0	50-100	60-114	3,0-5,0	76-152	EN 754/755
5754 - 0/H112	15-200	21-219	2,5-5,0	27,5-305	EN 754/755
5754 - 0/H112	250-800	273-813	3,0-10,0	381-1219	EN 485
6060 - T66	15-200	21-219	2,5-5,0	27,5-305	EN 755



REDUCCIONES

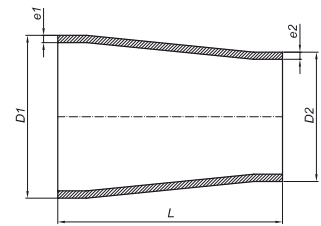

Reductor concéntrico

Aleación	Rango DN/NB	Rango de diámetro D1 (mm)	Rango de espesor e1 (mm)	Rango de diámetro D2 (mm)	Rango de espesor e2 (mm)	Rango de longitudes L (mm)	Norma
5083 - 0	1 1/2x1 - 10x8	48,3-273,1	2,77-12,7	33,4-219,1	2,7-8,5	64-178	EN 754/755
1050 - 0	40x25 - 200x150	46-219	3,0-4,0	31-159	3,0-4,0	70-155	EN 754/755
1050 - 0	250x219 - 800x700	273-813	4,0-8,0	219-711	4,0-8,0	178-610	EN 485
5754 - 0/H112	40x25 - 200x100	46-219	3,0-5,0	31-114	3,0-5,0	70-155	EN 754/755
5754 - 0/H112	250x219 - 800x700	273-813	4,0-8,0	219-711	4,0-8,0	178-610	EN 485
6060 - T66	40x25 - 200x150	46-219	3,0-5,0	31-168	3,0-5,0	70-155	EN 755

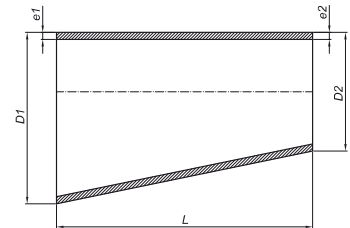

Reductor excéntrico

Aleación	Rango DN/NB	Rango de diámetro D1 (mm)	Rango de espesor e1 (mm)	Rango de diámetro D2 (mm)	Rango de espesor e2 (mm)	Rango de longitudes L (mm)	Norma
5083 - 0	1 1/2x1 - 8x6	48,3-219,1	2,7-7,1	33,4-168,3	2,7-5,4	64-152	EN 754/755
1050 - 0	80x50 - 200x150	89-219	3,0-4,0	57-159	3,0-4,0	90-155	EN 754/755
1050 - 0	250x200 - 800x700	273-813	4,0-8,0	219-711	4,0-8,0	178-610	EN 485
5754 - 0/H112	80x50 - 200x150	89-219	3,0-4,0	57-159	3,0-4,0	90-155	EN 754/755
5754 - 0/H112	250x200 - 800x700	273-813	4,0-8,0	219-711	4,0-8,0	178-610	EN 485
6060 - T66	80x50 - 200x150	89-219	3,0-4,0	57-159	3,0-4,0	90-155	EN 755

UNIONES EN T

9

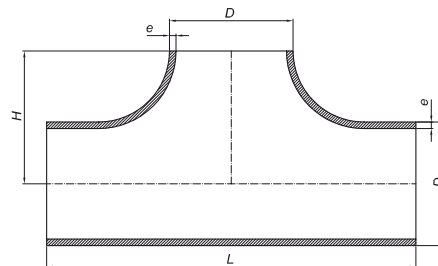
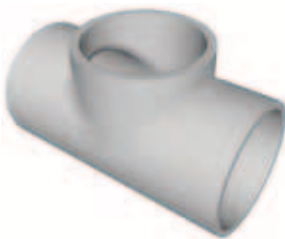

Reductor concéntrico

Aleación	Rango DN/NB	Rango de diámetro D (mm)	Rango de espesor e (mm)	Rango de longitudes L (mm)	Rango de distancia B (mm)	Norma
5083 - 0	1-8	33,4-219	2,77-3,76	76-352	38-178	EN 754/755
6060 - T66	50-100	60-108	3,0-4,0	128-210	64-105	EN 755

COLLARINES DE ALUMINIO

COLLARINES

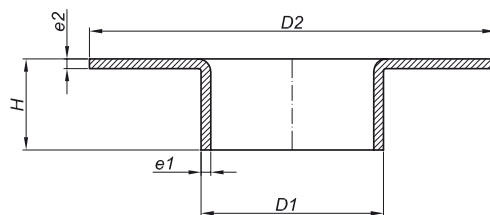

Collarines

Aleación	Rango DN/NB	Rango de diámetro D1 (mm)	Rango de espesor e1 (mm)	Rango de diámetro D2 (mm)	Rango de espesor e2 (mm)	Rango de altura H (mm)	Norma
1050 - 0	15-300	21-323,9	3,0-5,0	45-374	4,0-6,0	11-35	EN 485
5754 - 0/H112	15-300	21-323,9	3,0-5,0	45-374	4,0-6,0	novi-35	EN 485

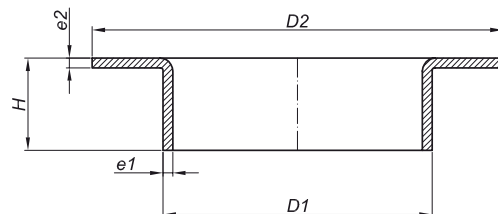

Collarines anchos

Aleación	Rango DN/NB	Rango de diámetro D1 (mm)	Rango de espesor e1 (mm)	Rango de diámetro D2 (mm)	Rango de espesor e2 (mm)	Rango de altura H (mm)	Norma
5754 - 0/H112	50-350	65,8-367	2,5-5,0	102-430	3,0-6,0	23-33	EN 485

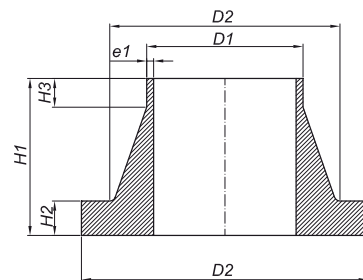

Collarines de cuello largo

Aleación	Rango DN/NB	Rango de diámetro D1 (mm)	Rango de espesor e1 (mm)	Rango de diámetro D2 (mm)	Rango de diámetro D3 (mm)	Rango de altura H1 (mm)	Rango de altura H2 (mm)	Rango de altura H3 (mm)	Norma
1050 - 0	10-300	14-318	2,0-7,5	22-332	40-370	35-60	10-22	6-16	EN 485/755
5754 - 0/H112	10-300	14-318	2,0-7,5	22-332	40-370	35-60	10-22	6-16	EN 485/755



BRIDAS



Bridas planas



Bridas planas



Bridas con cuello



Bridas roscadas



Bridas ciegas



Bridas cuadradas

Debido a la amplia diversidad de modelos y medidas disponibles en estos productos, se servirán bajo pedido. Consulte a nuestro departamento comercial el tipo, medida y cantidad necesaria.

Estos productos están disponibles en las aleaciones EN AW 1050 y EN AW 5754.